

### YZD系列铸造桥式起重机简介：

YZD铸造桥式起重机主要用于吊运熔融金属的冶金、铸造等场所，整机工作级别为A7，在主梁底部加设隔热层装置。起重机设计与制作符合JB/T7688.5《铸造起重机》。

#### 环境条件：

- 1、起重机的电源为三相交流，额定频率为50HZ，额定电压为380V；
- 2、工作环境温度为一10~+60℃；
- 3、在+40℃的温度下相对湿度不超过50%；
- 4、如超过上述要求，根据用户需要按订货合同条款执行。

### Brief introduction of YZD series bridge foundry crane :

YZD casting bridge crane is mainly used in metallurgy, casting and other places for lifting molten metal. The working level of the whole machine is A7, and an insulation layer device is added at the bottom of the main beam. The design and manufacture of the crane shall comply with JB/T7688.5 foundry cranes.

#### Environmental conditions:

1. The power of crane is three—phase AC; rated frequency is 50HZ; rated voltage is 380V;
2. The temperature of working environment is -10~+60℃;
3. The relative humidity is no more than 50% when the temperature is +40℃;
4. If the requirements are more than above-mentioned, it shall carry out the requirements in the purchase contract as the user asks.

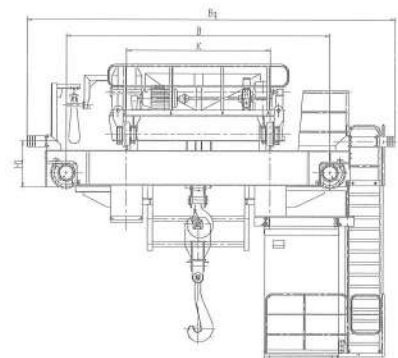
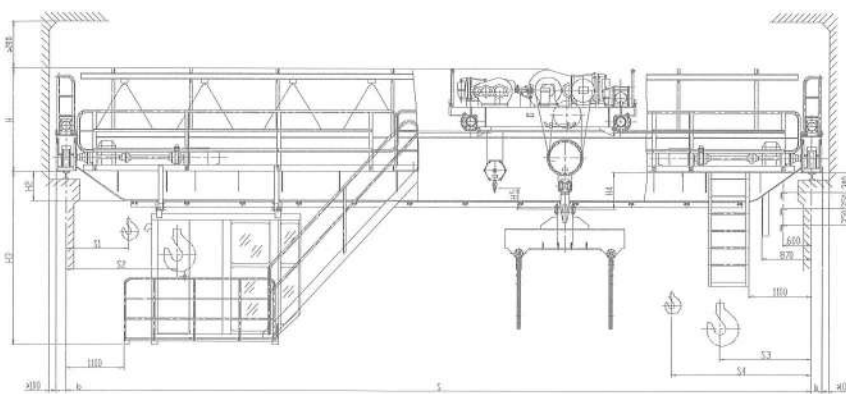

# YZD型5~74吨铸造起重机

YZD type 5~74 ton casting crane



## 技术参数 Technological parameter

起重量 Lifting Weight		t	5								10															
跨度 Span		m	10.5	13.5	16.5	19.5	22.5	25.5	28.5	31.5	10.5	13.5	16.5	19.5	22.5	25.5	28.5	31.5								
最大起升高度 Max.Lifting Height			16								16															
速度 Speed	起升 Hositing	m/ min	15.5								10.4															
	小车运行 trolley travelling		37.2								43.8															
	大车运行 crane travelling		n	92.7				93.7				92.7				93.7				86.5						
主要尺寸(mm) Main Dimensions		B <sub>0</sub>	5058				5208				6028				5708				5848				6388			
		B	3400				3550				5000				4050				5000							
		b	230								230															
		S <sub>1</sub>	800								1030															
		S <sub>2</sub>	1250								1900															
		K	1400								2000															
		B <sub>x</sub>	1100								2400															
		H	1763								2097								2187							
		H <sub>1</sub>	830+H0				870+H0				850+H0				940+H0											
		H <sub>2</sub>	-22	128	228	378	528	678	828	976	78	248	328	478	528	628	778	928								
		H <sub>3</sub>	2398	2548	2648	2798	2948	3096	3248	3396	2498	2648	2748	2898	2948	3048	3198	3348								
		H <sub>4</sub>	71								701								611							
最大轮压 Max wheel load		KN	76	85	93	98	108	128	139	144	112	121	131	139	147	161	168	185								
荐用钢轨 Steel track	小车 trolley	18kg / m																								
	大车 crane	P43																								
电源 Power source		三相交流 380V 50HZ 3-Phase A.C. 380V 50HZ																								

# YZD型5~74吨铸造起重机

## YZD type 5~74 ton casting crane

### 技术参数 Technological parameter

起重量 Lifting Weight		t	16 / 3.2								20 / 5															
跨度 Span			10.5	13.5	16.5	19.5	22.5	25.5	28.5	31.5	10.5	13.5	16.5	19.5	22.5	25.5	28.5	31.5								
最大起升高度 Max.Lifting Height	主钩 Main hook	m	16								12															
	副钩 Auxiliary hook		18								14															
速度 Speed	主起升 Main	m/ min	10.7								9.8															
	副起升 Auxiliary		14.6								15.5															
	小车运行 trolley travelling		44.6								44.6															
	大车运行crane travelling		76				89				76				89											
主要尺寸(mm) (Main)Dimensions		BQ	6278				6188				6798				6278				6188				6798			
		B	4400								5000															
		b	230				260				230				260											
		S1	1040								1030															
		S2	2310								2320															
		S3	1850								1930															
		S4	1500								1420															
		K	2000 ± 2								2000 ± 2															
		BX	2400								2430															
		H	2095		2097		2187		2185				2097		2099		2189									
		H1	878+H0				1005+H0				845+H0				1005+H0											
		H2	80	180	280	340	490	640	790	940	80	184	284	344	492	642	792	940								
		H3	2500	2600	2700	2760	2910	3060	3210	3360	2500	2604	2704	2764	2912	3062	3212	3362								
		H4	729		727		637		639				701		699		609									
最大轮压 Max wheel load		KN	163	174	187	203	214	227	241	254	195	209	220	244	255	267	282	296								
荐用钢轨 Steel track Recommended	小车 trolley	24kg / m																								
	大车 crane	P43 / QU70																								
电源 Power source		三相交流 380V 50HZ 3-Phase A.C. 380V 50HZ																								

# YZD型5~74吨铸造起重机

## YZD type 5~74 ton casting crane



### 技术参数 Technological parameter

起重量 Lifting Weight		t	32 / 5								50 / 10															
跨度 Span			10.5	13.5	16.5	19.5	22.5	25.5	28.5	31.5	10.5	13.5	16.5	19.5	22.5	25.5	28.5	31.5								
最大起升高度 Max.Lifting Height	主钩 Main hook	m	16								12															
	副钩 Auxiliary hook		18								16															
速度 Speed	主起升 Main	m/ min	7.8								7.8															
	副起升 Auxiliary		15.5								10.4															
	小车运行 trolley travelling		42.4								39.3															
	大车运行crane travelling		89				75.3				75.3				75				76.6							
主要尺寸(mm) (Main)Dimensions		BQ	6588				6608				6828				6828				6858				7058			
		B	4650				4700				5000				4800				5000							
		b	260				300				300				300				300							
		S1	1070								1005															
		S2	2680								3195															
		S3	2050								2200															
		S4	1700								2000															
		K	2500								2500															
		BX	2800								3580															
		H	2337	2341	2471				2746	2748	2754															
		H1	970+H0				1135+H0				1118+H0				1155+H0											
		H2	192	248	394	414	618	764	914	1014	46	202	254	404	604	754	904	1004								
		H3	2612	2668	2814	2834	3038	3184	3334	3534	2466	2622	2674	2824	3024	3174	3324	3424								
		H4	71								1020	1018	1012													
最大轮压 Max wheel load		KN	279	300	312	347	355	372	384	404	377	412	438	458	482	504	521	537								
荐用钢轨 Steel track Recommended	小车 trolley	P43																								
	大车 crane	QU70								QU80																
电源 Power source		三相交流 380V 50HZ 3-Phase A.C. 380V 50HZ																								

# YZD型5~74吨铸造起重机

YZD type 5~74 ton casting crane

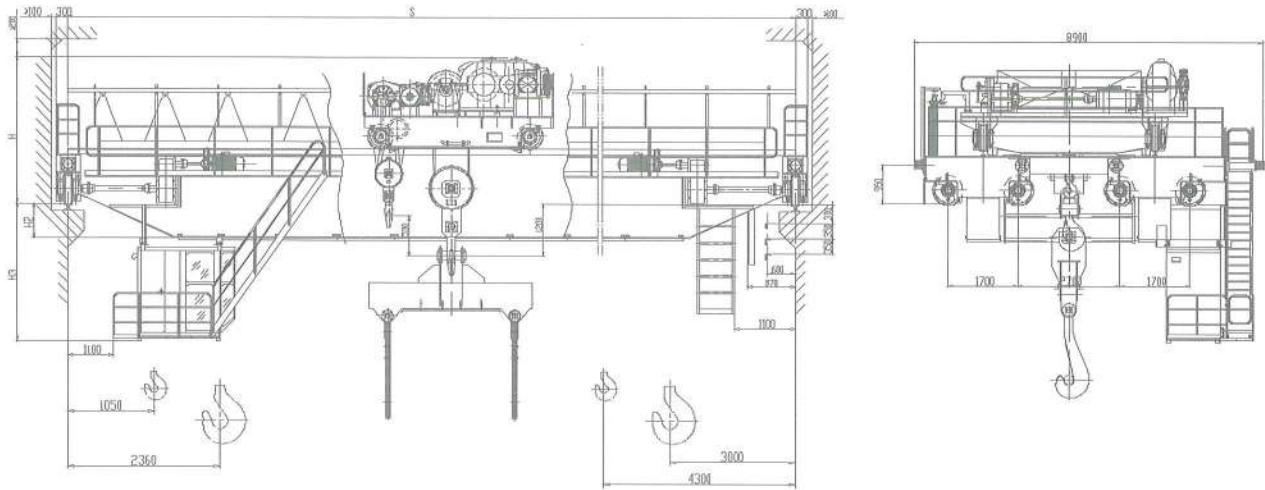

## 技术参数 Technological parameter

起重量 Lifting Weight		t	74 / 20						
跨度 Span			13.5	16.5	19.5	22.5	25.5	28.5	31.5
最大起升高度 Max.Lifting Height	主钩 Main hook	m	22						
	副钩 Auxiliary hook		24						
速度 Speed	主起升 Main	m/min	6.1						
	副起升 Auxiliary		9.7						
	小车运行 trolley travelling		33.8						
	大车运行 crane travelling		67.3						
主要尺寸(mm) (Main)Dimensions		H	3189	3189	3193	3199	3199	3203	3205
		H2	602	742	746	750	850	854	856
		H3	2982	3122	3126	3130	3230	3234	3236
		H4	1584	1584	1580	1576	1576	1572	1570
最大轮压 Max wheel load		KN	300	314	326	334	345	355	364
荐用钢轨 Steel track Recommended	小车 trolley	P43							
	大车 crane	QU100							
电源 Power source		三相交流 380V 50HZ 3-Phase A.C. 380V 50HZ							

# YZ型75 / 20~200/50吨铸造桥式起重机

YZ Type 75 / 20~200/50t Cast Bridge Crane

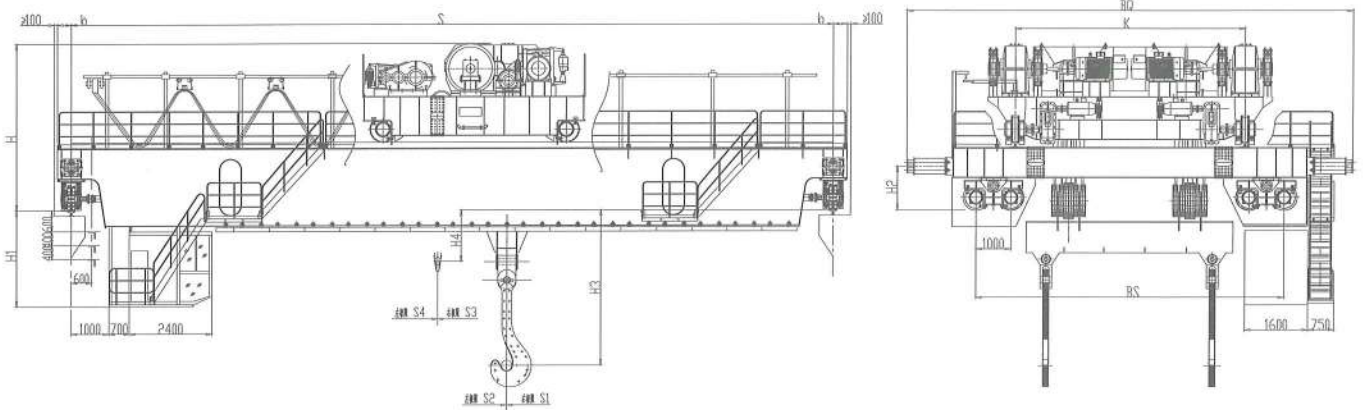

## 技术参数 Technological parameter

起重量(t) Lifting capacity		100 / 32			125 / 32		140/40			160/50			200/50		
工作级别 Working class		A7			A7		A7			A7			A7		
跨度 S(m) Span		19	22	25	19	22	19	22	25	19	22	25	19	22	25
起升高度 (m) Lifting Height	主钩 Main hook	18	20	25	24	20	23			24			24		
	副钩 Auxiliary hook	20	22	27	26	22	25			26			26		
速度 Speed	主钩 Main hook	6.8	6.8	8.6	9.5	7.6	6.3			6			6		
	副钩 Auxiliary hook	9.5	9.5	12	12	9.5	9.5			7.8			9.5		
	小车 trolley	37	37	41	42	36	34.8			36			38.8		
	大车 crane	68	68	77	77	77	77.8			68			78		
主要尺寸 (mm) Dimensions	H	4300	4300	4500	5150	5200	5350	5350	5350	5600	5600	5600	6600	6600	6600
	H <sub>1</sub>	4500	4500	5000	5000	5000	2750	2850	2950	2850	2950	3050	2850	2950	3050
	H <sub>2</sub>	1200	1200	1300	1350	1350	1300	1300	1300	1350	1350	1350	1400	1400	1400
	B <sub>0</sub>	13500	13800	14800	14800	14800	12850	12850	12850	12850	12850	12850	16800	16800	16800
	B <sub>S</sub>						8900	8900	8900	10000	10000	10000	13700	13700	13700
	K	7800	8000	9000	9000	9000	6500	6500	6500	6800	6800	6800	10500	10500	10500
	b	410	410	410	410	410	400	400	400	400	400	400	400	400	400
极限尺寸 limit dimension	H <sub>3</sub>	3500	3500	3500	380	380	5000	5000	5000	5500	5500	5500	6000	6000	6000
	H <sub>4</sub>	1200	1200	1200	1200	1200	1600	1600	1600	1700	1700	1700	1500	1500	1500
	S <sub>1</sub>	2000	2000	2000	2200	2200	2500	2500	2500	2600	2600	2600	2600	2600	2600
	S <sub>2</sub>	3700	3700	3700	4100	4100	4600	4600	4600	4750	4750	4750	5100	5100	5100
	S <sub>3</sub>	4100	4100	4100	4700	4700	4700	4700	4700	4850	4850	4850	5100	5100	5100
	S <sub>4</sub>	1600	1600	1600	1600	1600	2400	2400	2400	2500	2500	2500	2600	2600	2600
车轮数量 Number of wheels							8	8	8	16	16	16	16	16	16
最大轮压 (KN)Max wheel load		520	530	545	580	595	640	650	665	404	412	420	505	515	530
荐用钢轨 Steel track Recommended		QU120	QU120	QU120	QU120	QU120	QU120	QU120	QU120	QU120	QU120	QU120	QU120	QU120	QU120
电源 Power source		三相交流 380V 50HZ 3-Phase A.C. 380V 50HZ													