

# QC型5 ~ 16吨电磁桥式起重机

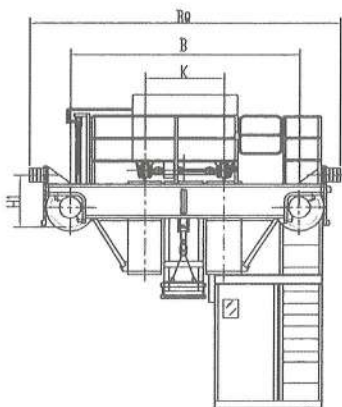

## QC type 5 ~ 16t Electromagnetic Bridge Crane

简图: sketch

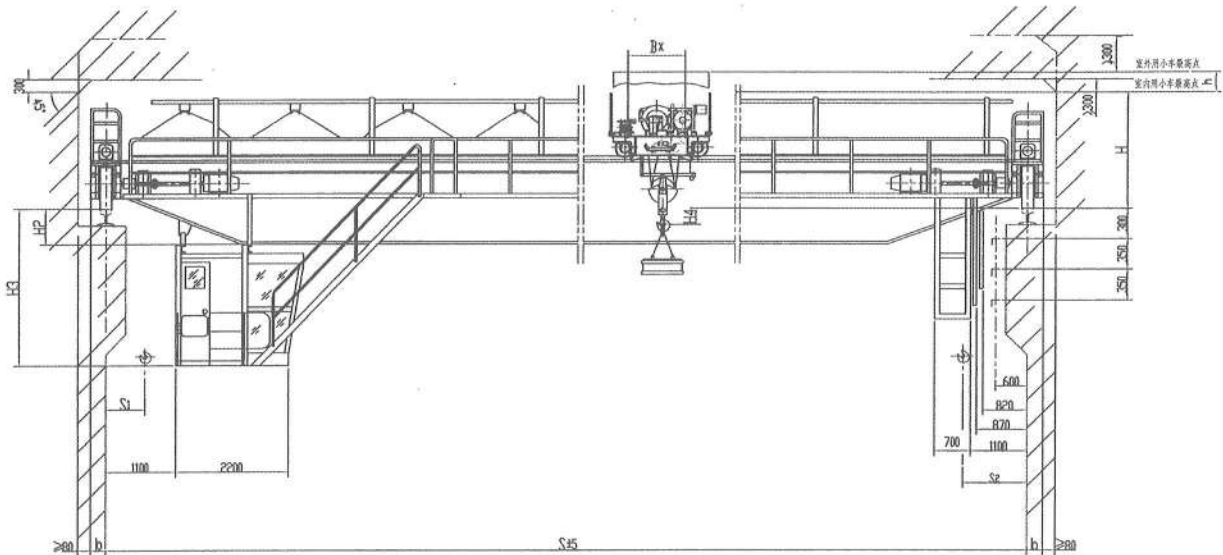

注:

1. 进入操纵室的走台门向位置为: 端面、侧面、顶面。
2. 起重量包括电磁盘自重。
3. 使用电磁盘时, 必须将吊钩旋转部用螺钉锁紧, 不允许转动。

Notes:

- (1)The direction of walkway door to the controlling room is: end, side and top.
- (2)The lifting capacity includes the dead weight of electromagnetic disk.
- (3)When used, the rotary part of the hook of electromagnetic disk must be locked up with screws and no rotation is allowed.

本样本所提供重量为设计值, 制造值为 $\pm 5\sim 15\%$ 。

The weight of this sample is design value and actual weight varies  $\pm 5\sim 15\%$ .

### 技术参数 Technological parameter

起重量 Lifting Weight		t	5												10												16																
工作级别 working class			A6																																								
跨度 span LQ		m	10.5	13.5	16.5	19.5	22.5	25.5	28.5	31.5	10.5	13.5	16.5	19.5	22.5	25.5	28.5	31.5	10.5	13.5	16.5	19.5	22.5	25.5	28.5	31.5																	
最大起升高度 Max Lifting Height		m	16												16												16																
速度 Speed	起升 Hoisting	电磁 electromagnetic	15.6												13												13																
	小车运行 Travelling of crab		39.5												43.8												44.5																
	大车运行 Travelling of trolley	m/min	92.7						93.7						92.7						93.7						86.4						76						89				
主要尺寸 (mm) Main size			B <sub>0</sub>	5390				5450				6100				6040				6130				6330				6235				6835											
			B	3600				3660				5000				4250				4200				5000				4400				5000											
			B <sub>x</sub>	1100												1500												1700															
			b	230												230												230						260									
			k	1400						1500						2000																											
			H	1764												2028				2026				2076				2095		2097		2187											
			H <sub>3</sub>	2526	2546	2596	2756	2906	3056	3206	3356	2528	2548	2598	2758	2908	3008	3158	3308	2570	2572	2552	2622	2770	2920	3070	3220																
			H <sub>1</sub>	735												790						880																					
			S <sub>1</sub>	1250												1500												1900															
			S <sub>2</sub>	1500																																							
			H <sub>2</sub>	122	126	226	376	526	676	826	976	122	128	228	378	528	628	778	928	180	182	182	242	390	540	690	840																
			h	850												720												700															
最大轮压 Max. wheel pressure	KN	72	79	87	94	104	114	122	134	115	122	129	138	145	157	164	173	143	153	162	173	184	194	204	213																		
荐用钢轨 Steel track recommended	P43																																										
电源 Power source	三相交流 3-Phase A.C 50Hz 380V																																										

# QC型16/3.2 ~ 32/5主钩电磁桥式起重机

QC Type 16/3.2 ~ 32/5t Main Hook Electromagnetic Bridge Crane



简图: sketch

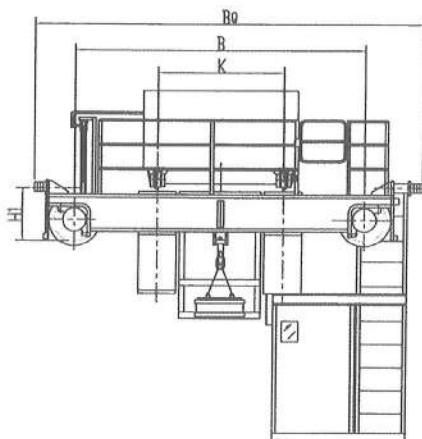
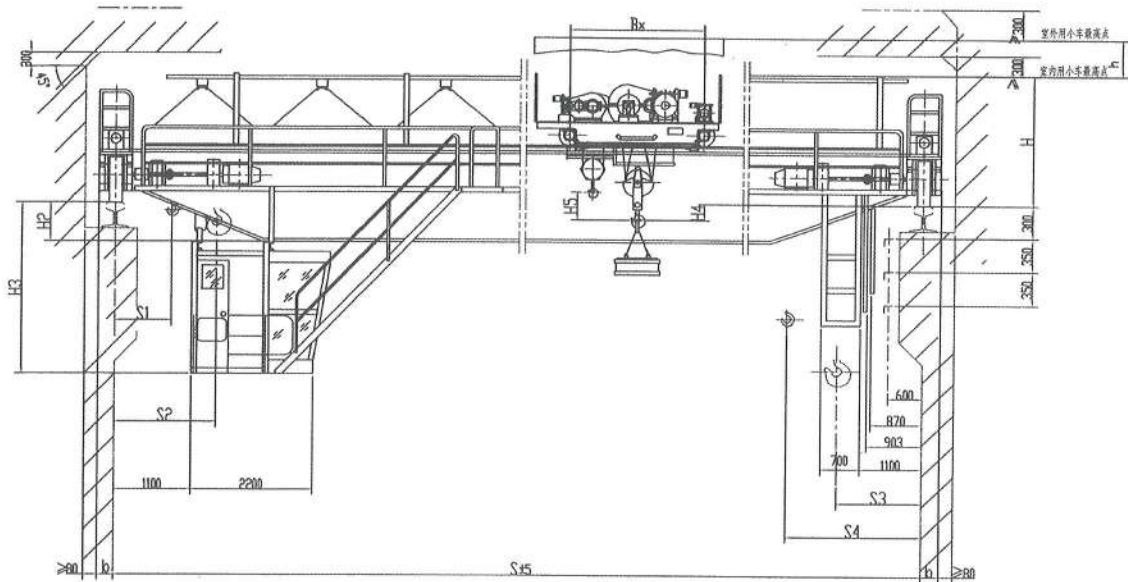

注:

1. 进入操纵室的走台门向位置为: 端面、侧面、顶面。
2. 起重量包括电磁盘自重。
3. 使用电磁盘时, 必须将吊钩旋转部用螺钉锁紧, 不允许转动。

Notes:

- (1)The direction of walkway door to the controlling room is: end, side and top.
- (2)The lifting capacity includes the dead weight of electromagnetic disk.
- (3)When used, the rotary part of the hook of electromagnetic disk must be locked up with screws and no rotation is allowed.

本样本所提供重量为设计值, 制造值为 $\pm 5\sim 15\%$ 。

The weight of this sample is design value and actual weight varies  $\pm 5\sim 15\%$ .

### 技术参数 Technological parameter

起重量Lifting Weight		t	16 / 3.2 (主钩电磁) (Main Hanger Electromagnetic)							20 / 5 (主钩电磁) (Main Hanger Electromagnetic)							32 / 5 (主钩电磁) (Main Hanger Electromagnetic)																																		
工作级别 working class			A6																																																
跨度span LQ		m	10.5	13.5	16.5	19.5	22.5	25.5	28.5	31.5	10.5	13.5	16.5	19.5	22.5	25.5	28.5	31.5	10.5	13.5	16.5	19.5	22.5	25.5	28.5	31.5																									
最大起升高度 Max Lifting Height		m	16 / 18							12 / 14							16 / 18																																		
速度 Speed	起升 Hoisting	电磁 electromagnetic	13							12.6							9.5																																		
		副钩 Aux. Hook	14.6							15.5							15.5																																		
	小车运行 Travelling of crab		m/min	44.6							44.6							43.4																																	
	大车运行 Travelling of trolley			76			89				76			89				89			75.3		75.3																												
主要尺寸 (mm) Main size		B <sub>0</sub>	6274							7004							6274							7004							6574							6744							7044						
		B	4400							5000							4400							5000							4650							4700							5000						
		B <sub>x</sub>	2935							2950							2950							3150																											
		b	230			260				230			260				230			260				230			260																								
		K	2000							2000							2000							2500																											
		H	2097	2099		2189			2099	2101	2191			2345	2349		2479																																		
		H <sub>3</sub>	2572	2552	2622	2772	2922	3072	3222	2572	2576	2556	2626	2774	2924	3074	3224	2582	2588	2618	2648	2798	2948	3098	3198																										
		H <sub>1</sub>	850		940					850		940					940		1070																																
		S <sub>1</sub>	1040							1070																																									
		S <sub>2</sub>	2460							2650																																									
		S <sub>3</sub>	1600							1700																																									
		S <sub>4</sub>	3020							3280																																									
		H <sub>2</sub>	82	182	242	392	542	692	842	82	86	186	246	394	544	694	844	92	98	248	268	418	568	718	818																										
		h	820																																																
最大轮压 Max. wheel pressure		KN	146	153	161	174	182	193	204	214	170	177	187	201	210	223	234	245	245	258	272	289	304	317	327	341																									
荐用钢轨 Steel track recommended			P43																																																
电源 Power source			三相交流 3-Phase A.C 50Hz 380V																																																