

## 5~10t 欧式吊钩桥式起重机

### E.O.T. Crane with Hook Cap.5~10t

#### 技术规格 Technical specifications

起重量 Cap	主钩 Main	t	5								10							
	副钩 Auxiliary		--								--							
跨度 Span		m	10.5	13.5	16.5	19.5	22.5	25.5	28.5	31.5	10.5	13.5	16.5	19.5	22.5	25.5	28.5	31.5
起升高度 Lifting Height	主钩 Main		18								18							
	副钩 Auxiliary	--								--								
工作制度 Duty			A5								A5							
速度 Speed	主钩 Main	m/min	1.07~10.7								0.81~8.1							
	副钩 Auxiliary		--								--							
	小车运行 Crab travelling		3~30								3~30							
	大车运行 Trolley travelling		6.8~68								6.8~68							
极限尺寸 Limt dimension	L1	mm	950								970							
	L2		1280								1355							
	L		--								--							
	h		196.5				124.5				434.5				384.5			
	h1		--								--							
主要尺寸 Main dimension	H0	mm	320				340				340							
	H		1206.5				1278.5				1348.5				1398.5			
	H1		2459	2509	2609	2709	2641	2751	2791	2841	2505	2605	2655	2755	2805	2855	2955	3055
	B		5040				5240				5380				5580			
	K		1500								1800							
	B1		150								150							
	F		108	158	258	358	290	390	440	490	140	240	290	390	440	490	590	690
最大轮压 Max.Wheel Loading		kN	48	52	56	60	66	71	78	83	78	83	88	93	100	105	112	119
电机总功率 Power		kw	16.5				18.5				22.1				24.1			
荐用钢轨 Crane Rail Recommended			43kg/m															
电 源 Power Supply			三相交流 3-Phase A.C.50HZ 380V															

# 16~20t 欧式吊钩桥式起重机

## E.O.T. Crane with Hook Cap.16~20t

### 技术规格 Technical specifications

起重量 Cap	主钩 Main	t	16							20								
	副钩 Auxiliary		5							5								
跨度 Span		m	10.5	13.5	16.5	19.5	22.5	25.5	28.5	31.5	10.5	13.5	16.5	19.5	22.5	25.5	28.5	31.5
起升高度 Lifting Height	主钩 Main		16							16								
	副钩 Auxiliary	18							18									
工作制度 Duty			A5							A5								
速度 Speed	主钩 Main	m/min	0.73~7.3							0.58~5.8								
	副钩 Auxiliary		1.07~10.7							1.07~10.7								
	小车运行 Crab travelling		3.2~32							3.2~32								
	大车运行 Trolley travelling		5.4~54							5.4~54								
主要尺寸 Main dimension	L1	mm	675							675								
	L2		1590							1590								
	L		925							925								
	h		467							525								
	h1		390							450								
主要尺寸 Main dimension	H0	mm	450							450								
	H		1620							1622								
	H1		2515	2615	2715	2820	2920	3020	3120	3220	2520	2620	2720	2820	2920	3020	3120	3220
	B		6080				6280				6080				6280			
	K		2500							2500								
	B1		192							192								
	F		150	250	350	455	555	655	755	855	155	255	355	455	555	655	755	855
最大轮压 Max.Wheel Loading		kN	117	125	132	140	148	156	164	171	135	144	151	161	169	177	185	193
电机总功率 Power		kw	41.2				43.2				43.2							
荐用钢轨 Crane Rail Recommended			43kg/m															
电 源 Power Supply			三相交流 3-Phase A.C.50HZ 380V															

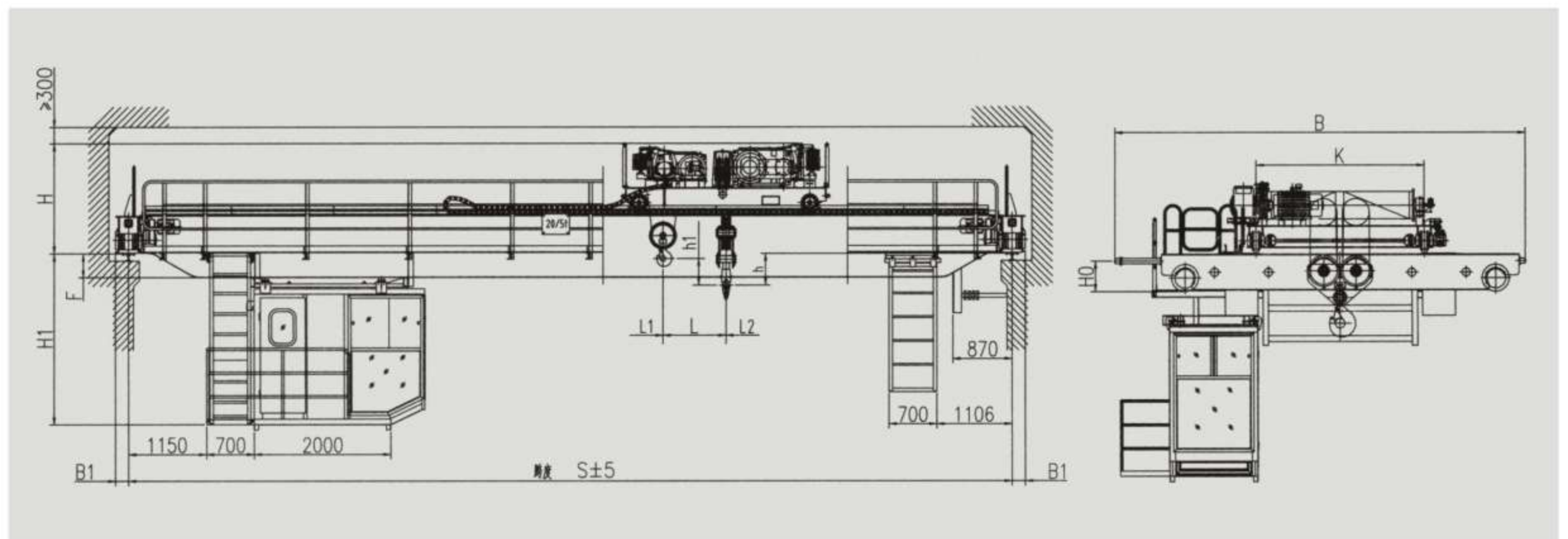

# 32~50t 欧式吊钩桥式起重机

## E.O.T. Crane with Hook Cap.32~50t

### 技术规格 Technical specifications

起重量 Cap	主钩 Main	t	32							50								
	副钩 Auxiliary		5							10								
跨度 Span		m	10.5	13.5	16.5	19.5	22.5	25.5	28.5	31.5	10.5	13.5	16.5	19.5	22.5	25.5	28.5	31.5
起升高度 Lifting Height	主钩 Main		16							16								
	副钩 Auxiliary	18							18									
工作制度 Duty			A5							A5								
速度 Speed	主钩 Main	m/min	0.51~5.1							0.4~4								
	副钩 Auxiliary		1.07~10.7							0.81~8.1								
	小车运行 Crab travelling		2.9~29							2.9~29								
	大车运行 Trolley travelling		5.6~56			5~50				5.4~54			4.8~48					
极限尺寸 Limit dimension	L1	mm	750							880								
	L2		1740							2000								
	L		950							1120								
	h		645	631	629	549	545											
	h1		750							365								
主要尺寸 Main dimension	H0	mm	450							450								
	H		1830							1980			2065					
	H1		2540	2640	2740	2890	3040	3140	3240	3295	2579	2729	2831	3031	3051	3055	3155	3255
	B		6290							6590			6690					
	K		2500							2800								
	B1		175							205								
	F		175	275	375	525	675	775	875	925	230	380	480	680	700	805	905	1005
最大轮压 Max.Wheel Loading		kN	102	105	107	112	122	126	132	137	150	156	172	179	184	190	197	202
电机总功率 Power		kw	55							71								
荐用钢轨 Crane Rail Recommended			QU70							QU80								
电 源 Power Supply			三相交流 3-Phase A.C.50HZ 380V							三相交流 3-Phase A.C.50HZ 380V								

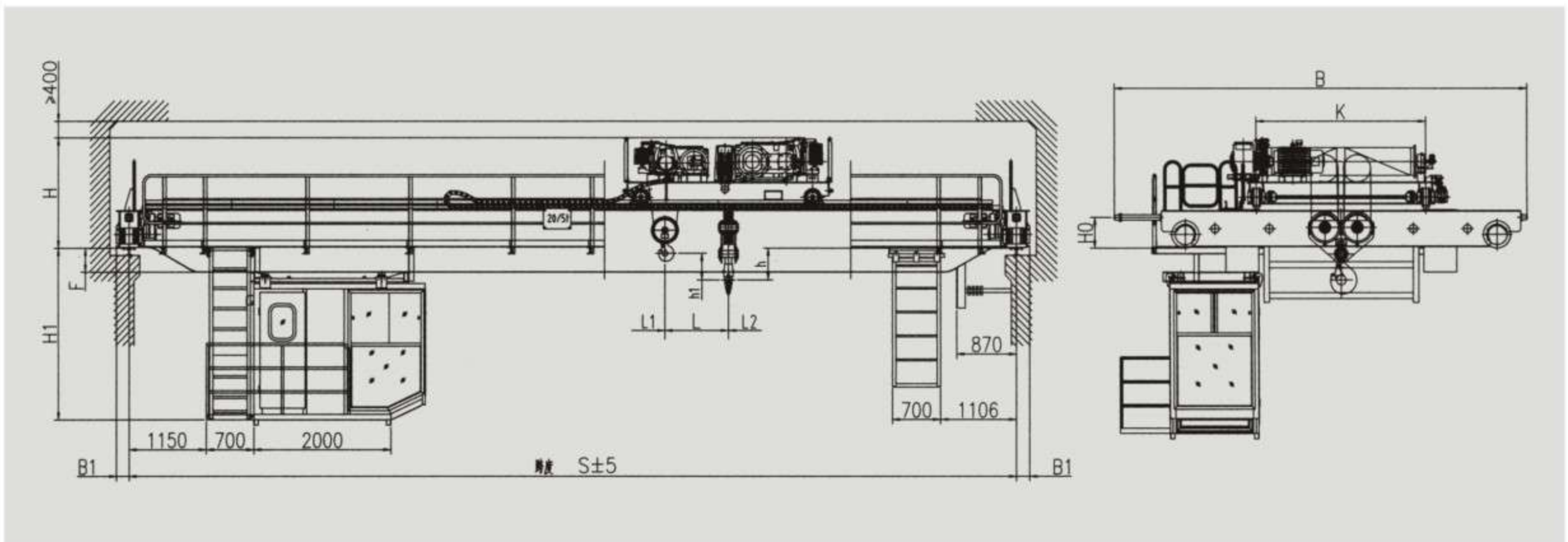

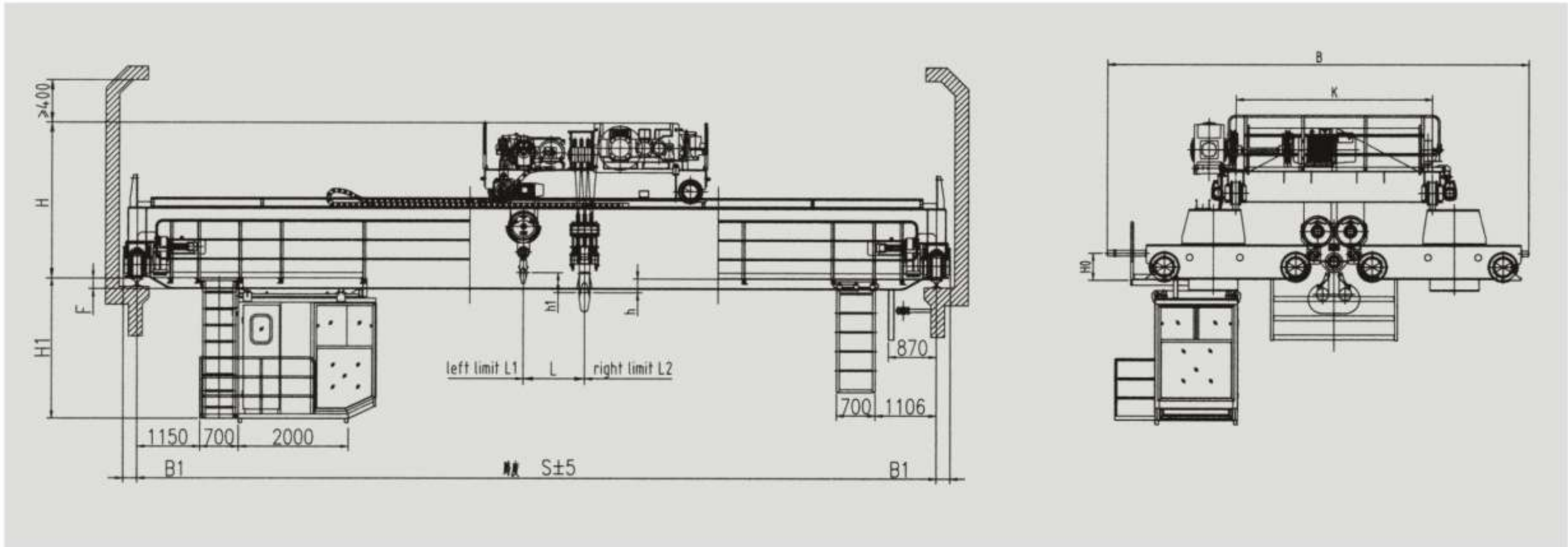

## 75~100t 欧式吊钩桥式起重机

### E.O.T. Crane with Hook Cap.80~100t

#### 技术规格 Technical specifications

起重量 Cap	主钩 Main	t	75						100						
	副钩 Auxiliary		20						20						
跨度 Span		m	13.5	16.5	19.5	22.5	25.5	28.5	31.5	16.5	19.5	22.5	25.5	28.5	31.5
起升高度 Lifting Height	主钩 Main		24						24						
	副钩 Auxiliary	26						26							
工作制度 Duty			A5						A5						
速度 Speed	主钩 Main	m/min	0.37~3.7						0.32~3.2						
	副钩 Auxiliary		0.57~5.7						0.57~5.7						
	小车运行 Crab travelling		2.92~29.2						2.9~29						
	大车运行 Trolley travelling		4.8~48						5.26~52.6						
主要尺寸 Main dimension	L1	mm	705						775						
	L2		2075						2265						
	L		1070						1100						
	h		528	428	424	354	250								
	h1		362						362						
	H0		400						500						
主要尺寸 Main dimension	H	mm	2335		2435	2440		2970		3075					
	H1		2390	2540	2740	2890	3040	2550	2650	2555	2705	2905	3105		
	B		7700						7710						
	K		3600						3600						
	B1		227						252						
	F		24	174	374	524	674	186	286	190	340	540	740		
	最大轮压 Max.Wheel Loading		kN	263	271	279	288	295	305	313	315	325	340	350	361
电机总功率 Power	kw	104.5						118			126				
荐用钢轨 Crane Rail Recommended		QU100						QU100							
电 源 Power Supply		三相交流 3-Phase A.C.50HZ 380V						三相交流 3-Phase A.C.50HZ 380V							

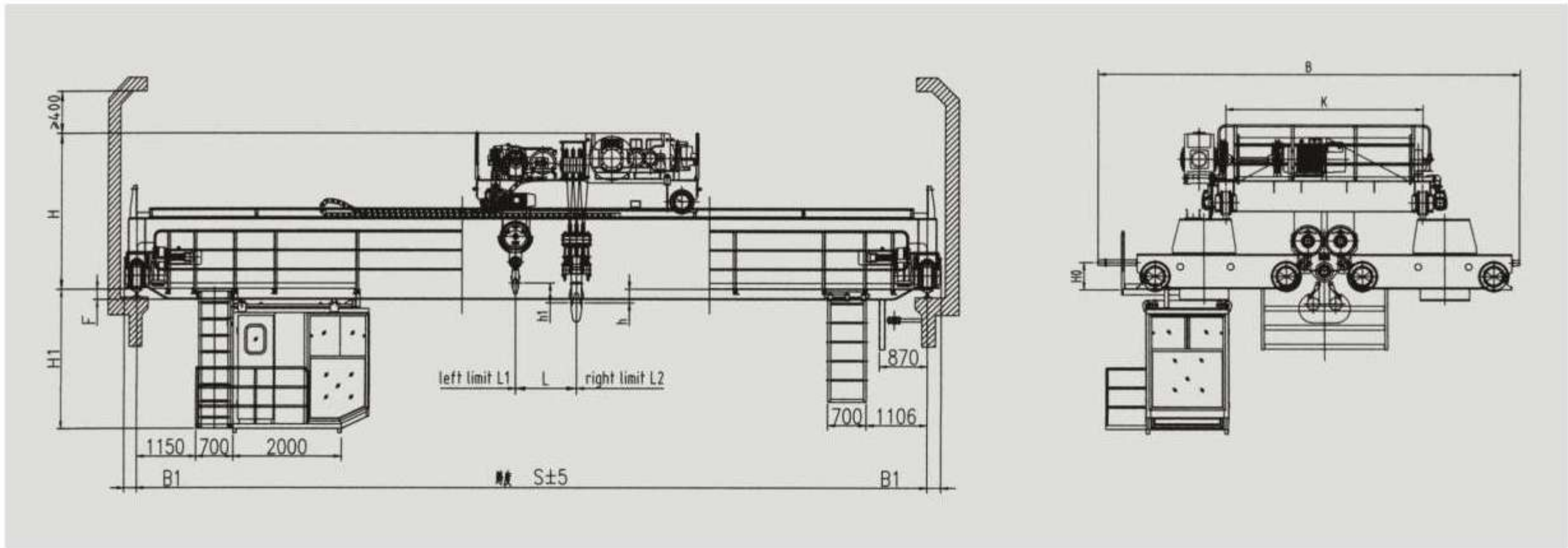

## 125t 欧式吊钩桥式起重机

### E.O.T. Crane with Hook Cap.125t

#### 技术规格 Technical specifications

起重量 Cap	主钩 Main	t	125					
	副钩 Auxiliary		32					
跨度 Span		m	16.5	19.5	22.5	25.5	28.5	31.5
起升高度 Lifting Height	主钩 Main		24					
	副钩 Auxiliary	26						
工作制度 Duty			A5					
速度 Speed	主钩 Main	m/min	0.28~2.8					
	副钩 Auxiliary		0.5~5					
	小车运行 Crab travelling		2.5~25					
	大车运行 Trolley travelling		5.26~52.6					
极限尺寸 Limt dimension	L1	mm	730					
	L2		2410					
	L		1260					
	h		144	94	42			
	h1		50					
主要尺寸 Main dimension	H0	mm	500					
	H		2896	2946	2998			
	H1		2550	2700	2650	2950	2900	3100
	B		8110					
	K		4000					
	B1		252					
	F		184	334	284	584	536	736
最大轮压 Max.Wheel Loading		kN	381	394	406	419	430	441
电机总功率 Power		kw	143					
荐用钢轨 Crane Rail Recommended			QU100					
电 源 Power Supply			三相交流 3-Phase A.C.50HZ 380V					